

Features

- DALI or PUSH dimmable
- Standby power consumption <0.35W
- Dim to off without afterglow
- Supports 2 sets of light fixtures connected in series
- Output current set via external resistor
- Output current and CLO set via programmer
- Supports logarithmic dimming (default setting) and linear dimming
- Supports corridorDIM
- 5-year warranty (please refer to the warranty condition)



Applications

· Indoor office lighting · hospital lighting · residential lighting · corridor lighting · others

Descriptions

LF-FSD037YA is a 37W non-isolated constant current LED driver featuring 37W constant power output. It supports DALI or PUSH dimming or corridor dimming. Its rated input voltage ranges from 220 to 240Vac, output voltage from 54 to 240Vdc and output current from 75 to 400mA. It is suitable for Class I light fixtures, including linear light, tri-proof light, etc.

Product Model

LF - FSD 037 YA

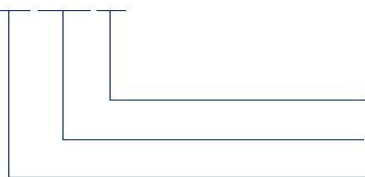

- Y: complies with certifications; A: serial number
- 037: output power: 37W
- F: non-isolated design; SD: indoor dimmable LED driver

Lifud Technology Co., Ltd.

Production Base I (HQ): Building B, Kutto Industrial Park, NO.26 Xinhe Road, Bao'an District, Shenzhen, China.
 Production Base II: No.4, Block 2, Tengfei Road, Shigao Economic Development Zone, Tianfu New Area, Sichuan, China.
 Website: www.lifud.com Telephone: +86(0)755 8373 9299 Email: sales@lifud.com

■ Electrical Characteristics

Model		LF-FSD037YA				
Output	Output Voltage	54-240Vdc				
	Output Current	75-400mA ^①				
	Default Output Current	75mA ^②				
	Ripple Current (<100Hz)	<1%				
	Flicker Index	Complies with IEEE Std 1789-2015				
	IEC-PSt	≤1				
	CIE (SVM)	≤0.4				
	Current Tolerance	±5%				
	Temperature Drift	±10%				
Input	Rated Input Voltage	220-240Vac				
	Input Voltage Range	198-264Vac				
	DC Input Voltage Range	180-264Vdc ^③				
	Input Frequency	0/50/60Hz				
	Input Current	0.23A max.				
	PF	≥0.95				
	THD	≤10%				
	Efficiency	≥90%				
	Inrush Current	≤24A ^④				
	Loading Quantities of Circuit Breaker	Model	B10	C10	B16	C16
		Quantity (pcs)	27	46	43	63
	Leakage Current	≤0.7mA				
Standby Power Consumption	≤0.35W (DALI OFF)					
Protection Characteristics	Open Circuit	<250V				
	Short Circuit	Hiccup mode (auto-recovery)				
Environment Descriptions	Operating Temperature	-30°C - +60°C				
	Operating Humidity	20-90%RH (no condensation)				
	Storage Temperature/ Humidity	-30°C - 80°C (6 months in Class I environment); 10-95%RH (no condensation)				
	Atmospheric Pressure	86-106kPa				

■ Electrical Characteristics

Surge	L-N	1kV
	L/N-PG	2kV
	PUSH	0.5kV
Safety & EMC	Certifications	ENEC, CE, CB, UKCA, RCM, EL
	Withstand Voltage	I/P-PG: 1.5kV&5mA&60S; I/P-DA1/DA2: 1.5kV&5mA&60S
	Insulation Resistance	I/P-PG: >100MΩ@500VDC; I/P-DA1/DA2: >100MΩ@500VDC
	Safety Standards	ENEC: EN61347-1:2015, EN 61347-2-13:2014/A1:2017, EN 62384: 2020 CE-LVD: EN 61347-2-13:2014/A1:2017, EN 61347-1:2015, EN 62493:2015 CB:IEC 61347-1:2015, IEC61347-2-3:2014, IEC 61347-2-13:2014/AMD1:2016 RCM:AS 61347.2-13:2018 EL:IEC 61347-2-13:2014 Annex J UKCA: BS EN IEC 55015: 2019+A11: 2020, BS EN 61547: 2009, BS EN IEC 61000-3-2: 2019, BS EN 61000-3-3: 2013/A2: 2021
	EMI	CE-EMC/RCM:EN55015, EN61000-3-2, EN61000-3-3
	EMS	CE-EMC/RCM:EN61000-4-2,3,4,5,6,11
Other Parameters	IP Rating	IP20
	RoHS	RoHS 2.0 (EU) 2015/863
	Tc Max	90°C
	Warranty	5 years [®] (Tc≤79°C)
	Lifetime	100,000 hours (subject to the requirements specified in this data sheet)
	Compatibility of DALI Dimming [®]	Yuanhao Master, Simon Master, Philips Master DDBC120-DALI, OSRAM Master, Helvar Master 905 Router, Tridonic Master and HDL MC64-DALI431 Master
	DALI Standard	IEC 62386-101 102 207: DALI 2.0
Test Equipment	AC power source: CHROMA6530, digital power meter: CHROMA66202, oscilloscope: Tektronix DPO3014, DC electronic load: M9712B, LED board, constant temperature and humidity chamber; Everfine EMS61000-5B, fast transient generator: Everfine EMS61000-4A, spectroanalyzer: KH3935, Hi-pot tester: EEC SE7440, flicker tester (flicker-free coefficient test) LFA-3000, etc.	
Test Remark	If there are no special remarks, the above parameters are tested at the ambient temperature of 25°C, humidity of 50%, maximum output power and input voltage of 230Vac/50Hz.	

■ **Electrical Characteristics**

Additional Remarks	<p>1. It is well-advised to install the over voltage protection, under voltage protection and surge protection devices in the power supply circuits of light fixtures to ensure electricity safety.</p> <p>2. The LED driver used in combination with the end device is one of the accessories of the whole light fixture, and the EMC of the whole light fixture is not only susceptible to the driver itself, but to the LED light fixture and the whole light fixture's wiring. Thus, the manufacturer of LED light fixture should re-confirm the EMC of the whole light fixture before the whole light fixture is finished.</p> <p>3. The test conditions of the circuit breaker configuration quantity are the same as those of the inrush current.</p> <p>4. The PC cover, casing and end cap for assembling the LED driver in the light fixture must meet the fire rating of UL94-V0 or above.</p> <p>5. In no-load condition, it is well-advised to not directly connect the LED driver to the light fixture in case that the light fixture is damaged.</p> <p>6. It is recommended that the withstand voltage of LEDs and aluminum substrates be >3kVac.</p> <p>7. It is recommended to install double-pole switch at AC input terminal. If user uses the single-pole switch, make sure to connect it to wire L (live wire), otherwise the afterglow of light fixture would be incurred after the AC is disconnected.</p> <p>8. If the parasitic capacitance between LEDs and the PCBA is too large, and the light fixture is grounding, there will be a slight flicker at the moment of power on.</p> <p>Notes:</p> <p>① When the load voltage of LED driver ranges from 54 to 92Vdc, the LED driver outputs with the max. constant current of 400mA; when the load voltage >92Vdc, the LED driver outputs with the constant power of 37W.</p> <p>② The default current of LED driver is 75mA and its output current has two settings:</p> <p>1) Set by Lifud parameter setting box and DALI programming software</p> <p>2) Set by the external resistor at LEDset terminal</p> <p>③ DC input is only for emergency</p> <p>④ @190uS</p> <p>⑤ @Tc≤79°C</p> <p>⑥ When using other DALI masters, please test their compatibilities with Lifud LED driver in advance.</p>
---------------------------	---

■ **Product Characteristic Curves**

PF Curve

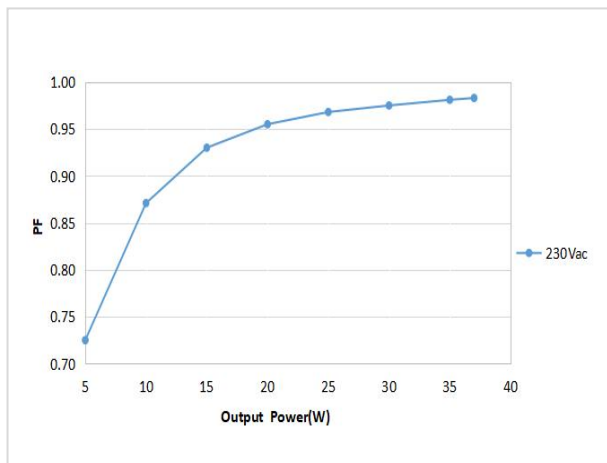

Efficiency Curve

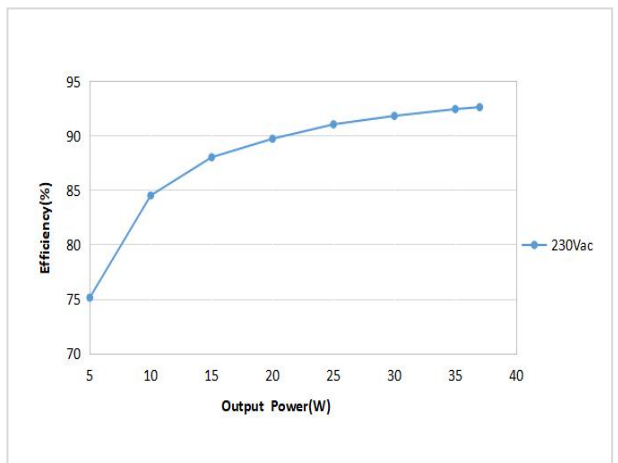

Lifud Technology Co., Ltd.

Production Base I (HQ): Building B, Kutto Industrial Park, NO.26 Xinhe Road, Bao'an District, Shenzhen, China.

Production Base II: No.4, Block 2, Tengfei Road, Shigao Economic Development Zone, Tianfu New Area, Sichuan, China.

Website: www.lifud.com

Telephone: +86(0)755 8373 9299

Email: sales@lifud.com

■ Product Characteristic Curves

Working Curve

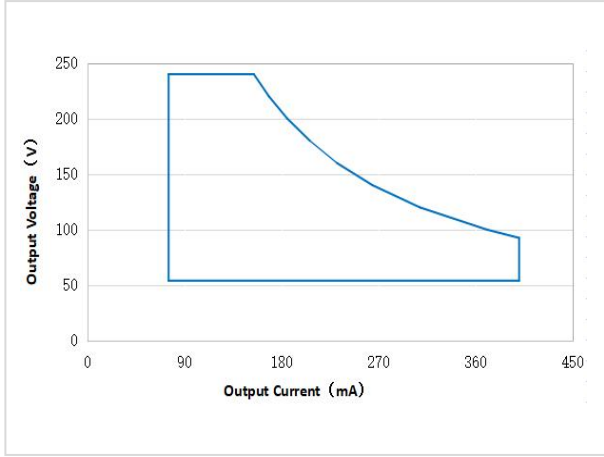

Dimming Curve

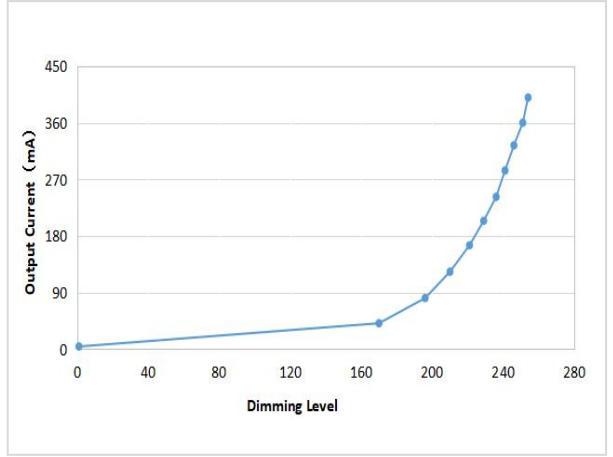

Output Current & Rset Curve

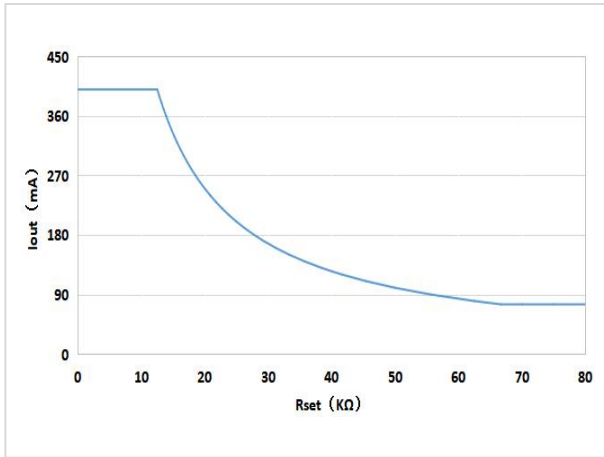

Lifetime Curve

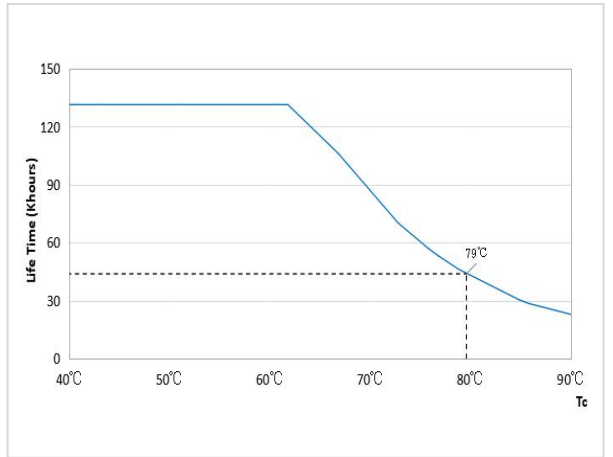

Tc Point (unit: mm)

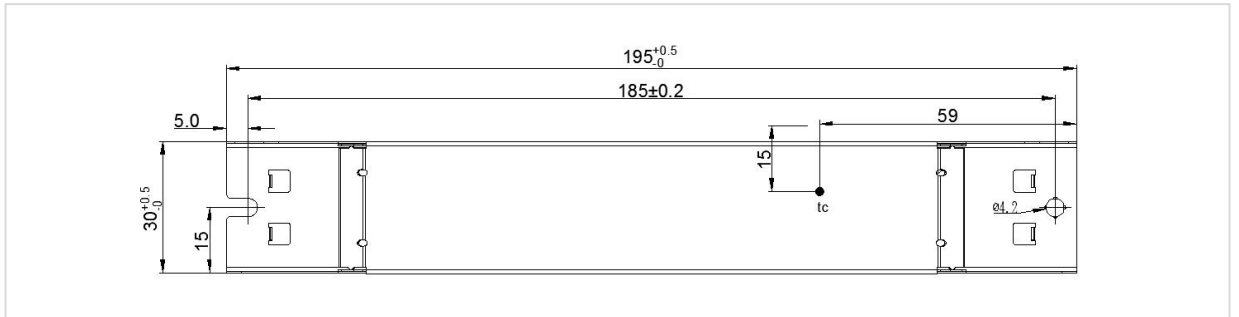

Product Definition

Product Terminals

INPUT		OUTPUT	
AC-L (grey terminal)	AC live wire input	LED+ (red terminal)	Positive electrode output of LED driver
AC-N (grey terminal)	AC neutral wire input	- (black terminal)	Negative electrode of LED board in series
		+ (red terminal)	Positive electrode of LED board in series
⊕ (grey terminal)	Earth wire input	LED- (black terminal)	Negative electrode output of LED driver
DA1 PUSH (green terminal)	DALI1/PUSH dimming input	LEDset+ (orange terminal)	Rset resistor input 1
DA2 PUSH (green terminal)	DALI2/PUSH dimming input	LEDset- (orange terminal)	Rset resistor input 2

Wiring Diagram of Product Output Terminal

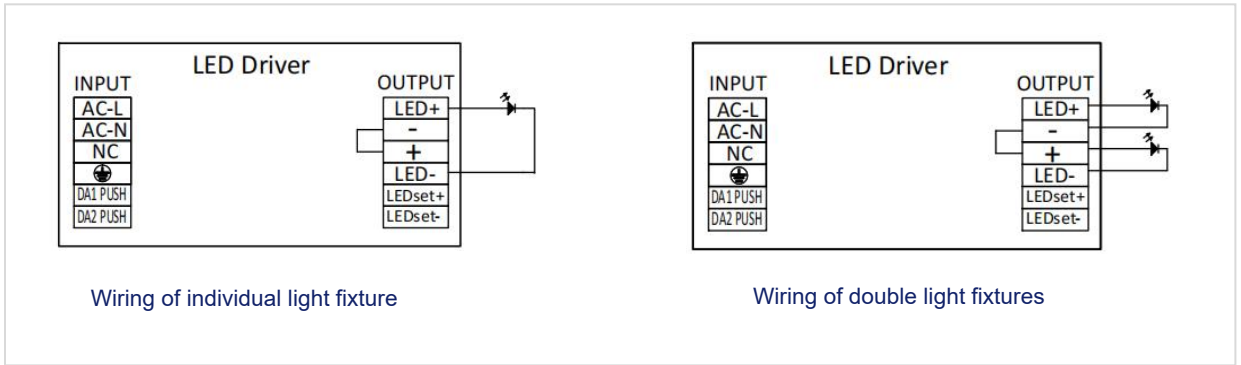

⚠ Do NOT connect LED set+ to LED- in case of the damage of LED driver.

Dimming Operation Instructions

⚠ Choose only ONE as opposed to use DALI or PUSH or corridor dimming at the same time in case of the damage of DALI master.

Wiring Diagram of PUSH Dimming

Remarks

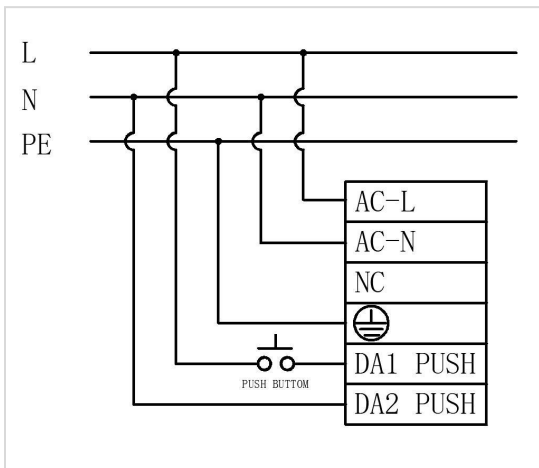

- Connect PUSH switch between AC-L and DA1 PUSH in series and connect DA2 PUSH to AC-N.
- Make sure that AC-L and AC-N are not directly connected to DA1 PUSH and DA2 PUSH terminals.
- Make sure that PUSH switch is off before the AC is powered on; operate PUSH after the AC is powered on.
- Make sure the PUSH switch is off before disconnecting the AC.
- If you have any questions about the wiring and operation, please confirm with Lifud FAE.
- **⚠** Wrong wiring or operation may cause damage to the driver.

■ **Dimming Operation Instructions**

Operations of PUSH Dimming

Operation	Duration	Function
Instant Push	0.1-0.5 sec(s)	LED light on/off
Long Push	0.6-9 sec(s)	When light is on, long PUSH to dim up/down
Long Push	0.6-9 sec(s)	Turn off the light via PUSH switch; long press the PUSH button to enable synchronous dimming of all luminaires from the minimum brightness
Reset Push	>15 sec(s)	Long press the PUSH button to reset the brightness of all luminaires to 50%

- The PUSH operation won't cause any variations on LED driver if it's less than 0.1S.
- Min. dimming depth of PUSH dimming: 1%
- The PUSH dimming mode has the memory function in case of any power failure. When powering the LED driver on again, the light will return to the previous state before power failure.
- The present dimming direction of PUSH dimming is opposite to the former one.
- In AUTO mode, press for 3+ mins to switch to corridor lighting.

Wiring Diagram of DALI Dimming

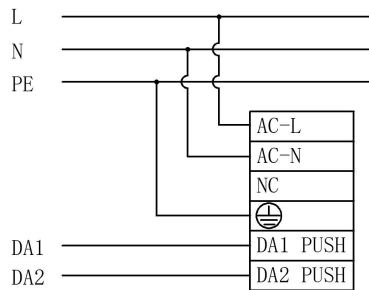

Operations of DALI Dimming

- Connect DALI signal to DA1 PUSH and DA2 PUSH terminals.
- DALI protocol includes 16 groups and 64 IP addresses.
- Max. number of LED drivers connected in parallel in DALI dimming mode: 64 pcs.
- Min. dimming depth of DALI dimming: 1%.

Dimming Operation Instructions

Wiring Diagram of Corridor Dimming (switch of sensor)

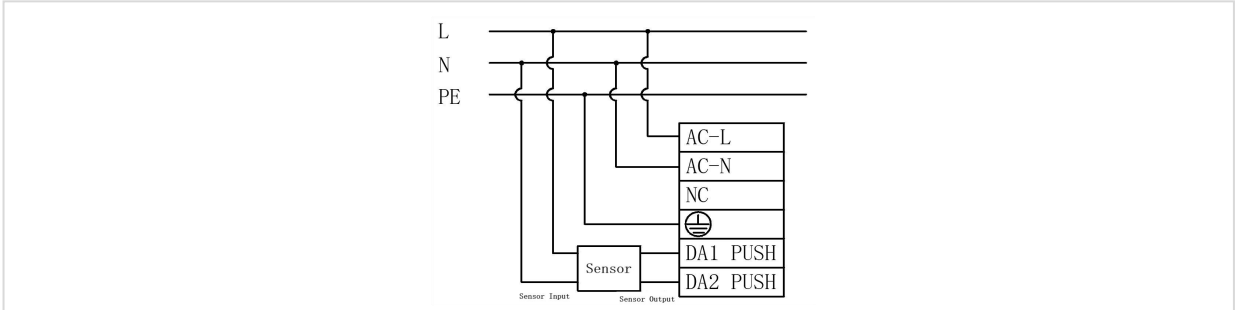

Operations for Entering Corridor Lighting Mode

- **Approach 1:** use Lifud programmer to enable the driver’s corridor lighting mode and set parameters.
- **Approach 2:** keep pressing PUSH switch for 3+ mins so as to switch to the corridor lighting mode.
- **Approach 3:** set the sensor’s hold time for 3+ mins (keep moving in the effective sensing area for 3+ mins) to enable the corridor lighting mode.
- Remarks:
 1. Entering: the driver can be switched from PUSH mode to corridor lighting mode by approach 2 and 3, its brightness will dim up to 50%; long press for 3 mins and then it dims down and then dims up, which means the driver has entered the corridor lighting mode.
 2. After activating the corridor dimming mode, PUSH DIM is turned off.

Operations for Exiting Corridor Lighting Mode

- **Approach 1:** use Lifud programmer to choose other modes and exit corridor lighting mode.
- **Approach 2:** connect to DALI master and send DALI command, the driver will return to the DALI dimming mode.
- **Approach 3:** connect to the PUSH switch and continuously press it 10 times within 10 secs, the driver will return to the PUSH dimming mode.
- Remark:
 1. The 3-sec or above single press or release will cause the press number (10 times) to be counted as 0.

Working Process of Corridor Dimming Mode

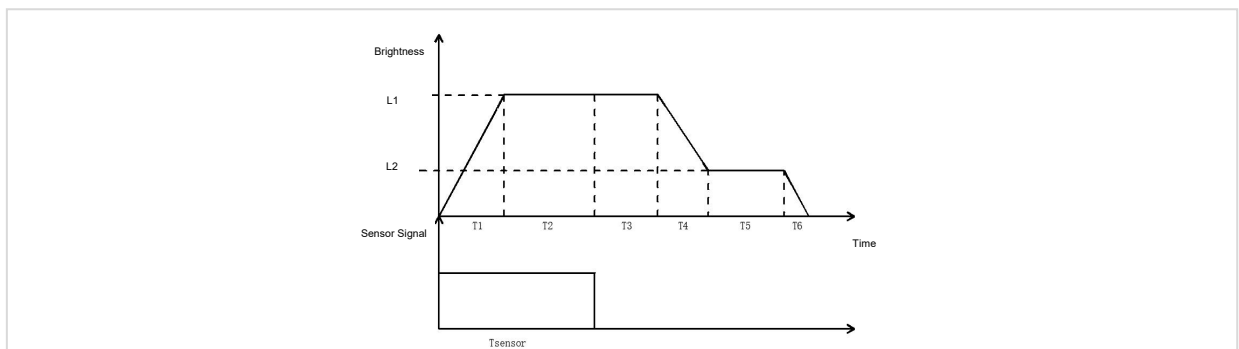

■ Dimming Operation Instructions

Working Process of Corridor Dimming Mode

		Default Value	Available Setting Scope
T1	Fade-in time of sensing	1 sec	0-100 sec(s)
T2	Hold time of sensing	Depends on sensor	Depends on sensor
T3	Wait time of sensing	180 secs	0-59999 sec(s); 60000 secs (∞)
T4	Fade-out time of sensing	5 secs	0-100 sec(s)
T5	Unattended time	60000 secs (∞)	0-59999 sec(s); 60000 secs (∞)
T6	Fade-out to off time	0 sec	0-100 sec(s)
L1	Sensing brightness	100%	0-100%
L2	Unattended brightness	10%	0-100%

■ LEDset Current Setting Instructions

Wiring Diagram of LEDset

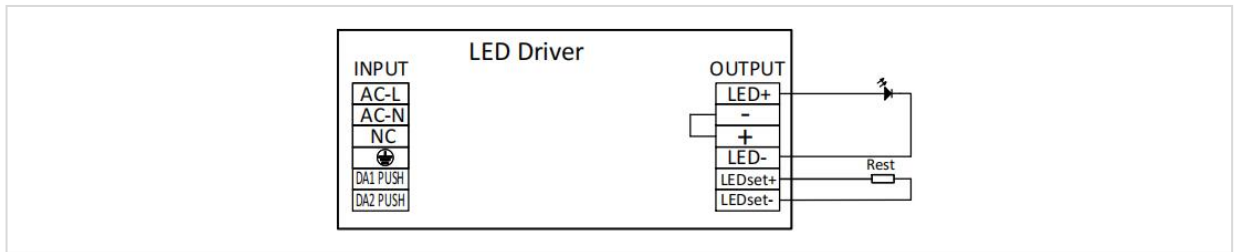

Reference Table for Output Current of Resistor Connected at LEDset

R (KΩ)	0-12.5	12.82	13.16	13.51	13.89	14.29	14.71	15.15	15.63	16.13	16.67	17.24
Iout (mA)	400	390	380	370	360	350	340	330	320	310	300	290
	17.86	18.52	19.23	20.00	20.83	21.74	22.73	23.81	25	26.32	27.78	29.41
	280	270	260	250	240	230	220	210	200	190	180	170
	33.33	35.71	38.46	41.67	45.45	50.00	55.56	62.50	66.67-100			
	150	140	130	120	110	100	90	80	75			

- Default current: 75mA
- Connect 0-12.5KΩ at LEDset, output current: max. current 400mA;
- Connect 12.5-66.67KΩ at LEDset, output current: 400-75mA [reference formula: $I_{out} = (5/R_{set}) * 1000mA$; unit of Rset: KΩ]
- Connect 66.67-100KΩ at LEDset, output current: min. current 75mA
- Connect >120KΩ at LEDset or not connect, output current: default current 75mA

■ Programmer Setting Instructions



Note: When using the programmer, the driver must be powered on with AC for normal reading and writing.

Programmer tools and softwares

Type	Name	Brand	Model
Tool	Lifud Programmer	LIFUD	LF-SCS080A
Software	PC Software	LIFUD	LF-PRG

■ Structure & Dimensions (unit: mm)

Product Dimensions

Model	Overall Appearance (L*W*H)	Distance Between 2 Positioning Holes	Diameter of Positioning Hole
LF-FSD037YA(Internal)	195*30*21 mm (±0.5mm)	185 mm (±0.2mm)	4.2 mm

Structure Diagram

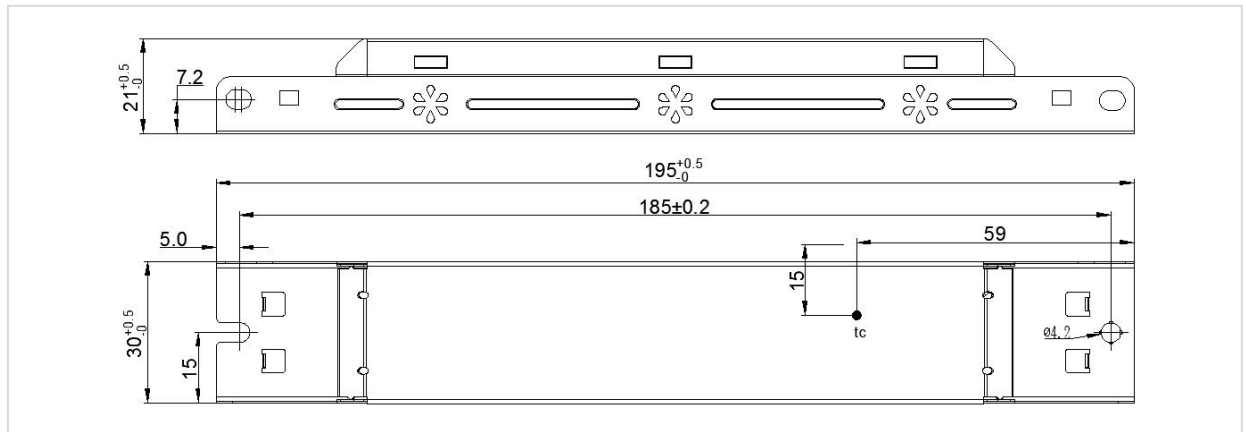

Model	Overall Appearance (L*W*H)	Distance Between 2 Positioning Holes (L)	Diameter of Positioning Hole (D)
LF-FSD037YA(External)	221.8*34.4*23.3 mm (±0.5mm)	185mm (±0.2mm)	4.2 mm

Lifud Technology Co., Ltd.

Production Base I (HQ): Building B, Kutto Industrial Park, NO.26 Xinhe Road, Bao'an District, Shenzhen, China.
 Production Base II: No.4, Block 2, Tengfei Road, Shigao Economic Development Zone, Tianfu New Area, Sichuan, China.
 Website: www.lifud.com Telephone: +86(0)755 8373 9299 Email: sales@lifud.com

■ **Structure & Dimensions (unit: mm)**

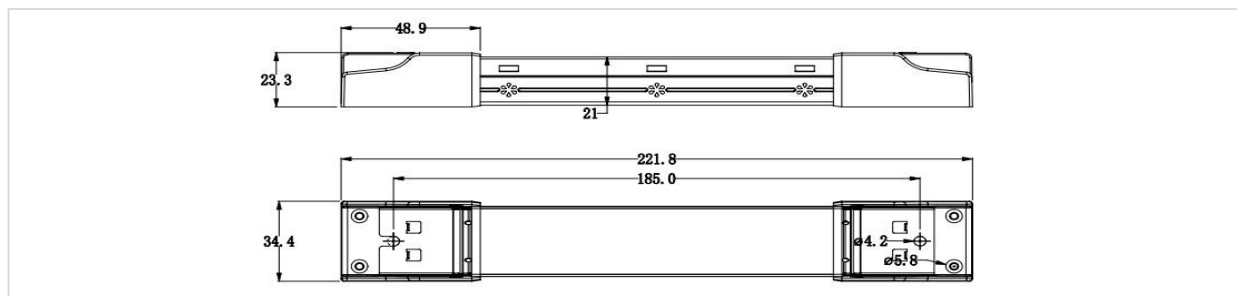

Remark: End caps should be purchased separately and shipped as accessories.

■ **Packaging Specifications**

Model	LF-FSD037YA
Carton Size	385*285*210mm (L*W*H)
Quantity	8 pcs/layer; 7 layers/ctn; 56 pcs/ctn
Weight	0.136 kg/pc; 8.45 kg ± 5%/ctn

■ **Transportation and Storage**

1. Transportation

- Suitable transportation means: vehicles, boats and aeroplanes.
- In transit, it is necessary to prepare awnings for rain or sun protection. Moreover, please keep civilized loading and unloading to prevent the vibration or impact of LED driver as much as possible.

2. Storage

- The storage of LED driver shall conform to the standard of Class I environment. When using LED drivers which have been stored for more than 6 months, please re-test them firstly. Do not use them unless they are tested to be qualified.

Cautions

- Please use Lifud LED driver according to its parameters in the specification, otherwise the LED driver may malfunction.
- Using any incompatible light fixtures or those that have not been certified may cause fire, explosion or other risks.
- Man-made damage is beyond the scope of Lifud warranty service.

Remark: Lifud Tecnology Co., Ltd. reserves the right to interpret any contents of this specification.

Lifud Technology Co., Ltd.

Production Base I (HQ): Building B, Kutto Industrial Park, NO.26 Xinhe Road, Bao'an District, Shenzhen, China.
 Production Base II: No.4, Block 2, Tengfei Road, Shigao Economic Development Zone, Tianfu New Area, Sichuan, China.
 Website: www.lifud.com Telephone: +86(0)755 8373 9299 Email: sales@lifud.com